



5580 Enterprise Pkwy.  
Fort Myers, FL 33905

Office: 239-694-0089  
Fax: 239-694-0031

[www.mcscontrols.com](http://www.mcscontrols.com)

# MCS MAGNUM CHILLER Chiller Plant Manager(CPM)

## *Manual & Sequence of Operations*

*Version 1.5*



**MCS Total  
Solution  
for all your  
Control  
Needs**

Revision-2023-08-08



***Energy Efficient and RoHS Compliant***

**Revision/Disclaimer Page**

<b>Date</b>	<b>Author</b>	<b>Description of Changes</b>
04-23-2015	DEW	Create Manual
05-04-2015	DEW	Edits from Remy
07-22-2015	DEW	Edits from Remy
11-30-2016	DEW	Edits
10-10-13-2017	DEW	Edits
04-02-18	DEW	Add setpoints 106 and 107 from D2
05-10-18	DEW	Add setpoints 108 and 109 from D2
09-10-18	DEW	Add setpoint 112, changes to setpoint 108 &109
09-11-18	DEW	Add 12 volt boards
11-13-18	DEW	Changed to setpoint #5 and #6 and #109
05-23-2022	DEW	Add section on Chiller Rotation setpoints 35 and 36

The MCS Commitment is to provide practical solutions for the industries needs and to be both a leader and partner in the effective use of microprocessor controls.

Micro Control Systems, Inc.  
5580 Enterprise Parkway  
Fort Myers, Florida 33905  
PH:(239) 694-0089 FAX:(239) 694-0031  
[www.mcscontrols.com](http://www.mcscontrols.com)

All information contained within this document is considered to be proprietary information of Micro Control Systems, Inc. No information or data from this document shall be published, used, reproduced, transmitted, or disclosed to others outside your organization without the prior expressed written consent of Micro Control Systems, Inc. This document and the information contained herein shall be treated as proprietary. Reasonable provisions shall be provided to ensure that this information remains proprietary by your employees, agents, and other personnel that may have access to this document.

Copyright ©2022

# Table of Contents

<b>Table of Contents</b> .....	<b>3</b>
<b>Chapter - 1. Introduction to CPM (Chiller Plant Manager)</b> .....	<b>5</b>
<b>Chapter - 2. About CHILLER Chiller Plant Manager</b> .....	<b>6</b>
2.1. Chiller Chiller Plant Manager (CPM) V17 .....	6
2.2. Specifications MCS-Magnum-N Revision 9.1 .....	6
2.3. MCS-Magnum-N Revision 9.1 .....	7
2.4. MCS-SI16-A04- Version 1.3 .....	8
2.5. MCS-RO10 - Version 1.2 .....	8
2.6. MCS-Magnum-N-12 Revision 10.4 .....	9
2.8.1 Optional Single Output Power Supply .....	9
2.7. MCS-IO-BASE and MCS-IO-EXT .....	10
2.8. MCS-RO-BASE and MCS-RO-EXT .....	11
2.9. MCS-SI-BASE and MCS-SI-EXT .....	12
<b>Chapter - 3. MCS-KEYPAD - Keys and their functions</b> .....	<b>16</b>
<b>Chapter - 4. Powering the CPM</b> .....	<b>17</b>
4.1. Pump Control Algorithm .....	17
4.2. Chiller Control Algorithm .....	19
4.3. CPM Unit Lockouts .....	19
4.4. Standard Capacity Control Logic .....	19
<b>Chapter - 5. Common Definitions for Capacity Control Logic</b> .....	<b>20</b>
5.1. Stage Up Hold .....	20
5.2. Staging Delay .....	20
5.3. Fully Loaded .....	20
5.4. Fully Unloaded .....	20
5.4.1 Target .....	20
5.4.2 Control Zone .....	20
5.4.3 Controlling Sensor .....	21
5.4.4 The Rate of Change of the Control Input .....	21
5.4.5 Step Delay .....	21
5.5. Ratio Adjustments .....	21
<b>Chapter - 6. CPM - STATES</b> .....	<b>22</b>
6.1. CPM Unit States .....	22
6.2. Individual Chiller States .....	22
6.3. Individual Pump States .....	23
6.4. Pump Group Capacity Control States .....	23
<b>Chapter - 7. CPM Config Screens</b> .....	<b>25</b>
7.1. MAG CPM (MAGNUM Chiller Chiller Plant Manager) .....	25
7.1.1 General Info .....	26
7.1.1.1 Chillers .....	26
7.1.1.1.1 'Primary Chillers' .....	26
7.1.1.1.2 Chillers are Hardwired? .....	26
<b>Chapter - 8. MAG CPM - General Info</b> .....	<b>26</b>
7.2. Relays .....	27
7.3. Control Options .....	27
7.4. Bypass Valves .....	27
7.5. Lost BMS Communication .....	27
7.6. Isolation Valves Located On: .....	28
7.7. Schedule Controls .....	28
7.8. Staging Method .....	28
7.9. CPM CHILLER ROTATION LOGIC .....	28
7.10. Sensors .....	29

<b>Chapter - 9. MAG CPM - Chiller Info</b> .....	<b>30</b>
9.1. Chiller Info screen.....	30
<b>Chapter - 10. MAG CPM - Pump Info</b> .....	<b>31</b>
10.1. Pumps and # of Pump Groups Info screen. ....	31
10.1.1 Pump Group .....	31
<b>Chapter - 11. MAG CPM - Condenser Info</b> .....	<b>32</b>
11.1. # of Condensers .....	32
11.1.1 Condenser Control Switches, Lights.....	32
11.1.2 Condenser Groups .....	32
<b>Chapter - 12. MAG CPM - Exhaust Info</b> .....	<b>33</b>
12.1. Not programmed into firmware yet. ....	33
<b>Chapter - 13. MAG CPM - Cooling Info</b> .....	<b>34</b>
13.1. Not programmed into firmware yet. ....	34
<b>Chapter - 14. Magnum CPM Setpoints</b> .....	<b>35</b>
14.1. Setpoint Types .....	36
14.1.1 SETPOINT .....	36
14.1.2 LOCKOUT.....	36
14.1.3 ALARM.....	36
14.1.4 TIME .....	36
14.1.5 TARGET.....	36
14.1.6 CPM TARGET .....	37
14.1.7 CPM RATIO .....	37
14.1.8 DELAY .....	37
<b>Chapter - 15. CPM - SET POINTS</b> .....	<b>38</b>

## Chapter - 1. Introduction to CPM (Chiller Plant Manager)

This software is designed to control a site that consists of multiple chiller packages that are being controlled by individual MCS MAGNUMS.

Each MCS MAGNUM controls its own chiller package and sends the CPM information as to its state.

The Chiller Plant Manger will control the process pumps to ensure that the required water flow is maintained and then stage the chiller packages to meeting the cooling requirements of the site. The Chiller Plant Manager is based upon the CPM V17 and Chiller HVAC V17 software family.

The Chiller Plant Manager will maintain water flow by controlling the pumps. To determine the site needs, the Chiller Plant Manager will compare the control temperature to the temperature target and develop the step capacity needed.

The Chiller Plant Manager can also review an input signal that limits its loading capacity. This is used for load limiting.

Communications between the Chiller Plant Manager and the MCS-MAGNUMS on the chiller packages is accomplished over the RS485 network. Messages are transmitted to the MCS-MAGNUMS that indicate if that package can run and the maximum number of steps if fixed step system or maximum demand capacity if a variable step system. The Chiller Plant Manager will also report if a package is not responding or if an error condition exists on that package. If the Chiller Plant Manager or the RS485 network fail, the individual MCS-MAGNUMS will control their chiller packages independently.

### ***All chiller safeties are preformed by the individual MCS-MAGNUMS.***

- Up to 15 pumps
- Supports up to 5 Pump Groups,
- Up to sixteen stages of cooling-ice making with one variable speed,
- Can control each pump independently or as a group,
- Run/stop switch, run override (occupancy) indicator,
- Individual schedule options can be selected,
- Provide alarm status of Magnum on the network
- Controlling sensor for the stages of heating and cooling-ice making,
- Each pump can have its own sensor analog, digit or both to indicate a failure.
- Each VFD can have its own sensor to indicate a failure.
- Common support items of the Chiller Plant Manager Software Family:
- Supports up to 80 Relay Outputs.
- Supports up to 112 Sensors Inputs.
- Supports up 28 Analog Outputs.
- Supports 255 Set points.
- Supports storage of last 99 alarms.
- Supports 1008 History Samples for all inputs & outputs.

### **Available options per loop:**

- Supports up to 12 pumps or fans per loop.
- Supports 16 cooling/ice making and heating stages per loop.
- Supports 1 VFD for pumps or fans per loop with unique control sensor.
- Supports 1 VFD for heating stages per loop.
- Supports 1 VFD for cooling stages per loop.

## Chapter - 2. About CHILLER Chiller Plant Manager

### 2.1. Chiller Chiller Plant Manager (CPM) V17

This manual is for MCS-MAGNUM running Chiller Plant Manager firmware.

- Brief overview of CPM firmware function

#### Complete Plant Controls

- Network or Hardwired connectivity up to **10 Chillers with MCS-Magnum controllers**
- Control for multiple chiller water pumps, with primary/secondary, rotation, variable speed
- Control for multiple cooling towers with primary/secondary, rotation, variable speed MCS-MAGNUM CONTROLLER

The MCS-MAGNUM is a durable microprocessor based controller designed for the hostile environments in the HVAC/R industry. It is designed to be the primary manager of the package it is controlling.

The Magnum provides flexibility with setpoints and control options that can be selected prior to commissioning a system or when the unit is live and functioning. Displays, alarms and other interfaces are accomplished in a clear and simple language that informs the user as to the status of the controller.

The MCS-MAGNUM-N consists of a master micro controller along with a keypad or Touchscreen. Complementing the Magnum micro controller is the MCS-SI16-AO4 and the MCS-RO10 expansion boards. This allows for system expansion to a maximum of 112 inputs and 108 outputs. Communication with these units occurs at 38,400 baud over the MCS-I/O port, which is dedicated to this purpose.

A RS-485 port is also provided for communication with other manufacturers systems. Other new features include the integration of BACnet IP, Modbus IP and Modbus RTU into the Magnum. A MCS-BMS-GATEWAY is also available that allows communication via BACnet MSTP and LonWorks, or the data format is available to allow the user to communicate directly.

A complete software support package is available for your PC, allowing for system configuration, dynamic on-line display screens, remote communication, graphing and more.

### 2.2. Specifications MCS-Magnum-N Revision 9.1

Dimensions .....	12.0"w, 8.0"h, 2.0"d
Mounting Holes .....	Mounts on a backplane using eight #6 sheet metal screws
Operating Temperature .....	-40°F to +176°F (-40°C to +80°C)
Storage Temperature.....	-40°F to +176°F (-40°C to +80°C)
Microprocessor .....	Zilog eZ80 Acclaim! @ 50mhz
Sensor Inputs (SI).....	12 inputs 0-5vdc (10-bit A/D)
Digital Inputs .....	4 inputs 0 or 5vdc only
Relay Outputs (RO) .....	10 outputs 6.3amps @ 230vac
Analog Outputs (AO).....	4 outputs 0-10vdc
Printed Circuit Board.....	Six layer with separate power and ground planes
Input Power (Standard).....	115 or 230vac ±10% 50/60Hz @ 77°F (25°C) ambient, 20VA max (Voltage is field selectable)
MCS-I/O Comm Port.....	1 @ 38,400 baud
RS-485 Comm Port.....	1 @ 19,200 baud
Ethernet .....	10/100 Mbps Ethernet
Real Time Clock.....	Battery backup
Power Detection.....	Automatic power fail reset

#### Options

- 24 24vac input power ±10%  
50/60Hz @ 77°F (25°C) ambient

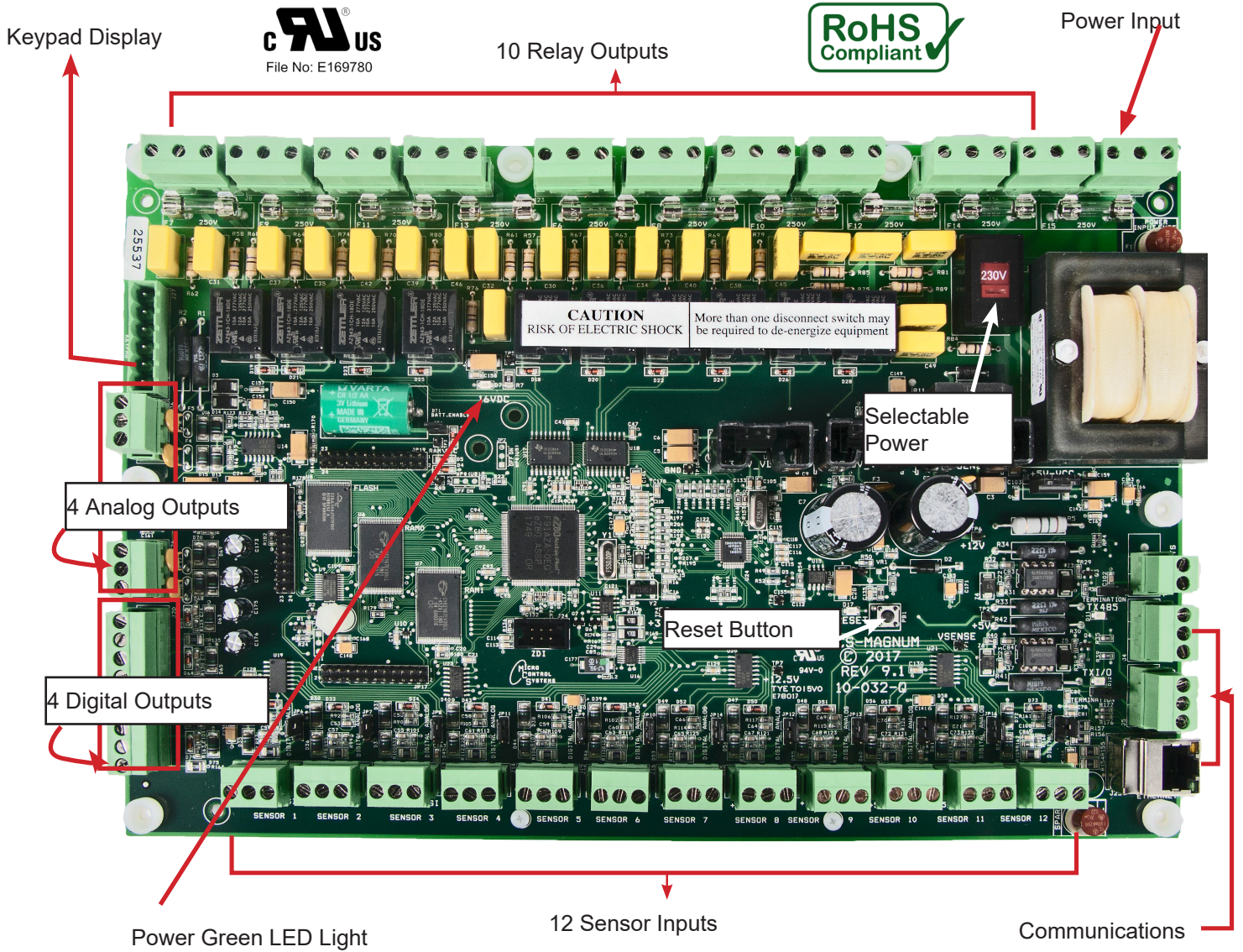

**2.4. MCS-SI16-A04- Version 1.3**

The MCS-SI16-A04 provides a flexible and cost effective way to allow sensor input and analog output expansion for MCS MAGNUM and MicroMag controllers

Input Power (Standard) ..... 115 or 230vac ±10% 50/60Hz  
 Optional 24vac input power ±10% 50/60Hz

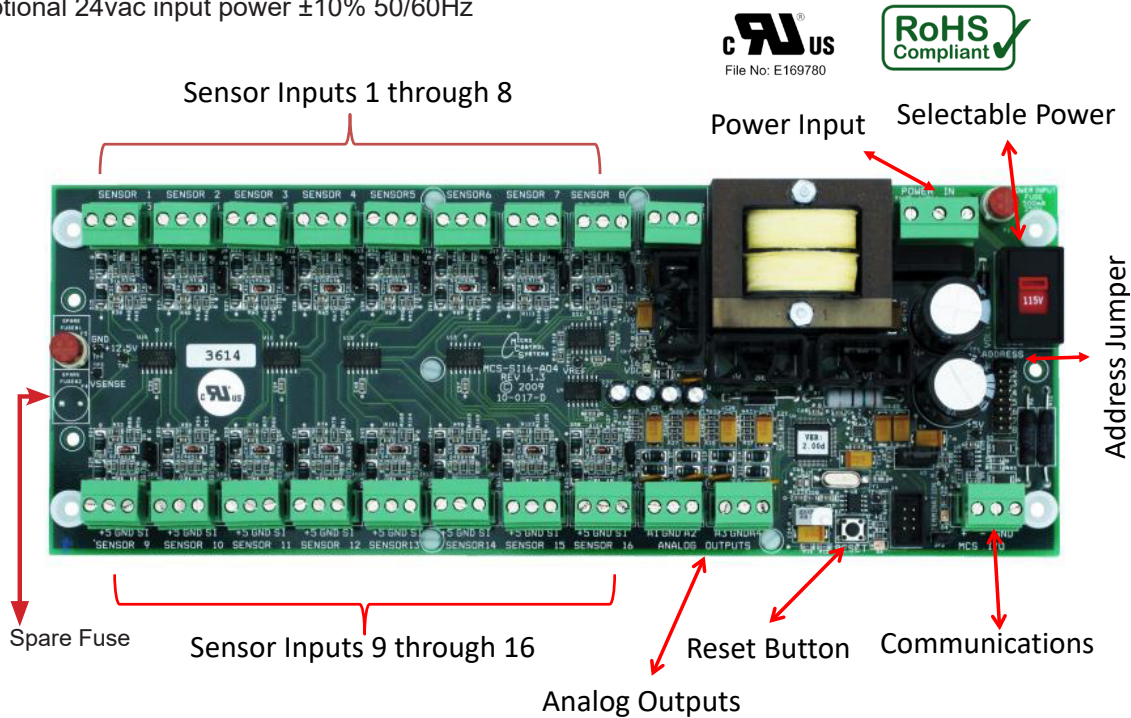

**2.5. MCS-RO10 - Version 1.2**

The MCS-RO10 provides a flexible and cost effective way to allow relay output expansion for MCS-MAGNUM and 1MicroMag controllers.

Input Power (Standard) ..... 115 or 230vac ±10% 50/60Hz  
 Optional 24vac input power ±10% 50/60Hz

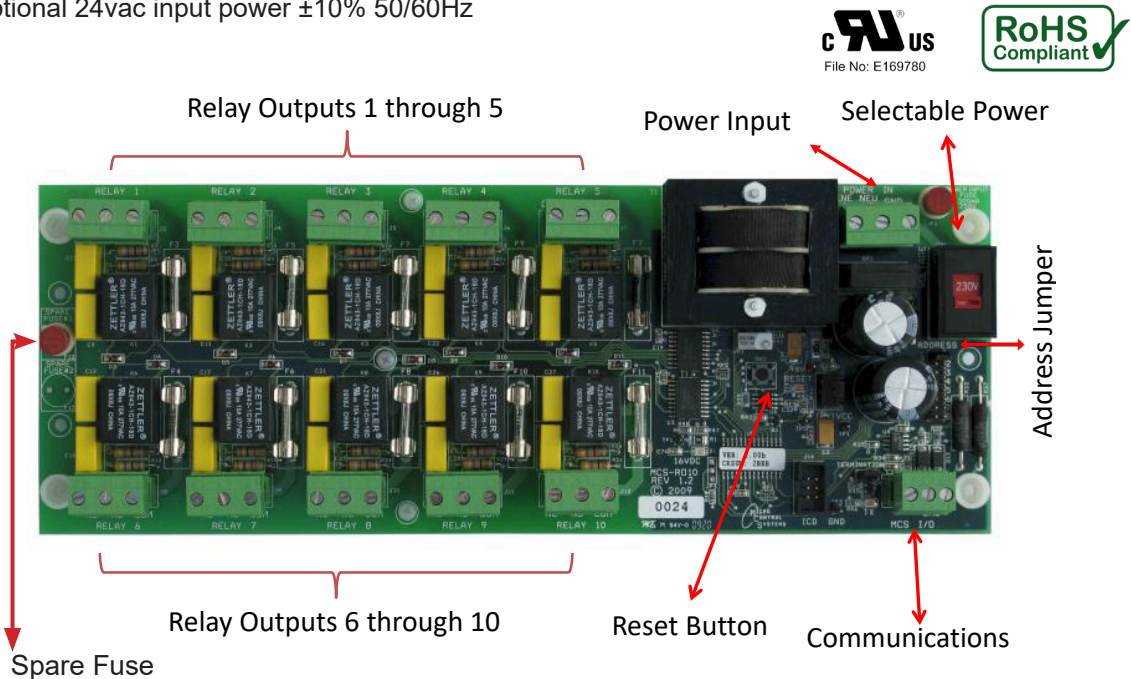



### 2.6. MCS-Magnum-N-12 Revision 11.1

Input Power (Standard) +12vdc power in board from 95 - 265vac switching power supply

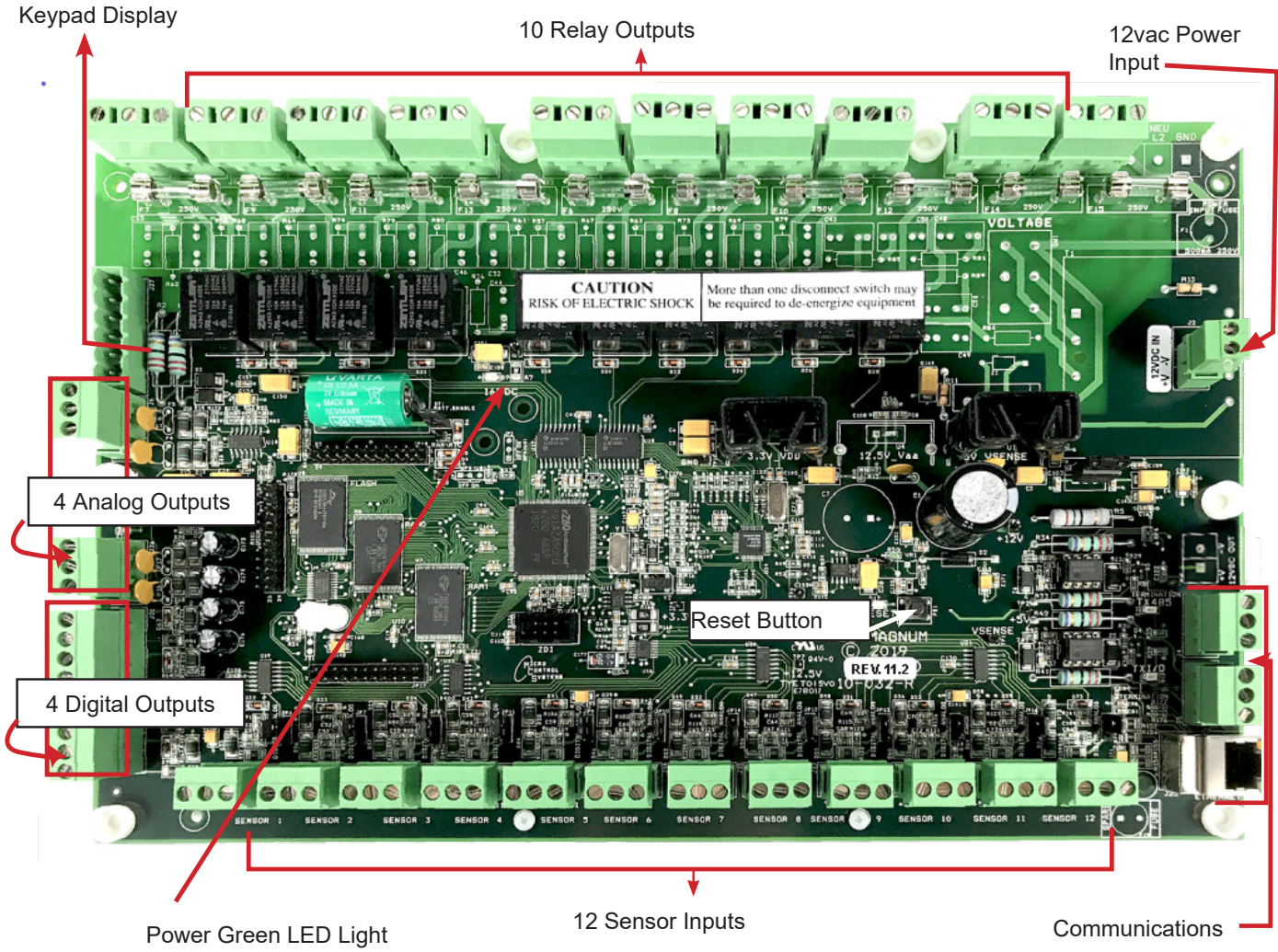

### 2.8.1 Optional Single Output Power Supply



Input Voltage.....	85-264VAC
Output Rated Current .....	7.5A
Output Rated Power.....	90W
AC Current.....	3A/115VAC
	1.6A/230VAC
Input Frequency.....	47Hz to 63Hz
Output Voltage.....	12VDC

Power Supply is based on number of expansion boards that are being used in the system.

## 2.7. MCS-IO-BASE and MCS-IO-EXT

The MCS-IO-BASE provides a flexible and cost effective way to allow relay output, sensor input and analog output expansion for MCS MAGNUM-N-12.

Using a Single Output Power Supply the MCS-IO can be used with 115-230 or 24 volt MCS-MAGNUM-N or MicroMag systems.

Using the stackable MCS-IO-EXT you can double the number of inputs and outputs in the same footprint in your enclosure or mounted to a backplane.

Photo below shows MCS-IO-BASE and MCS-IO-EXT mounted in a stackable array.

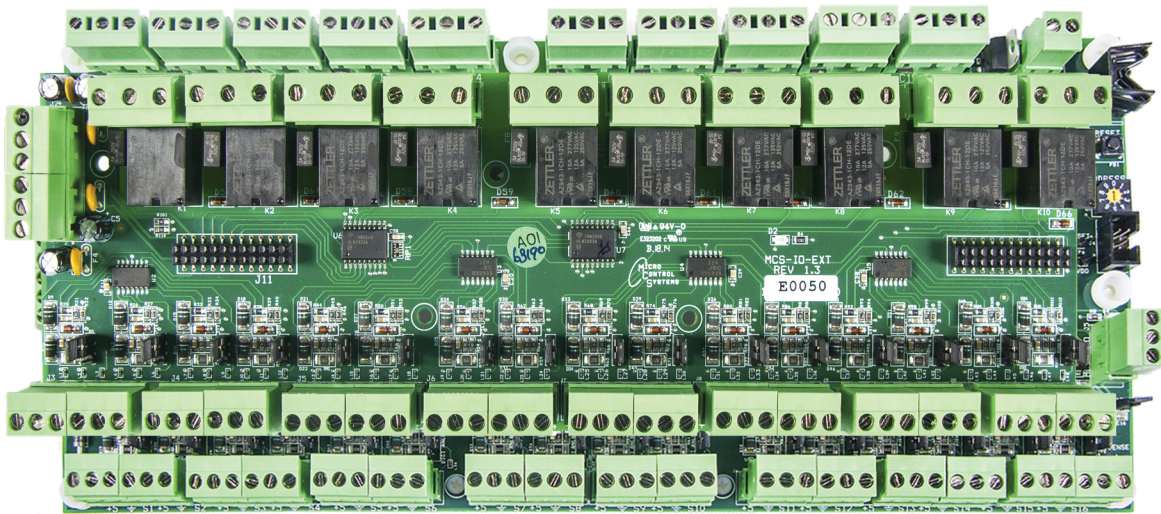

## MCS-RO-BASE and MCS-RO-EXT

- Dimensions ..... 10.7”l, x 3.5”w, 2.50”h
- MCS-IO-BASE ..... Mounts on a backplane using six #6 sheet metal screws
- MCS-IO-EXT. .... Mounts on top of the MCS-IO-BASE on top of the MCS-IO-BASE by 5 nylon standoffs and 2 stackers headers (included on MCS-IO-BASE)
- Operating Temperature ..... -40°F to +158°F (-40°C to +70°C)
- Operating Humidity..... 0-95% Non-Condensing
- Storage Temperature ..... -40°F to +158°F (-40°C to +70°C)
- Sensor Inputs ..... 32 inputs 0-5vdc (total with MCS-IO-EXT)
- Analog Output ..... 20 outputs 5amps @ 230VAC (total with MCS-IO-EXT)
- Printed Circuit Board ..... Four layer with separate power and ground planes
- Input Power ..... Powered by MCS-IO-BASE Power
- Power Detection..... Automatic Power Fail Reset on MCS-IO-BASE

## 2.8. MCS-RO-BASE and MCS-RO-EXT

The MCS-RO-BASE provides a flexible and cost effective way to allow relay output expansion for MCS MAGNUM-N-12.

Using a Single Output Power Supply the MCS-RO can be used with 115-230 or 24 volt MCS-MAGNUM-N or MicroMag systems.

Using the stackable MCS-RO-EXT you can double the number of inputs and outputs in the same footprint in your enclosure or mounted to a backplane.

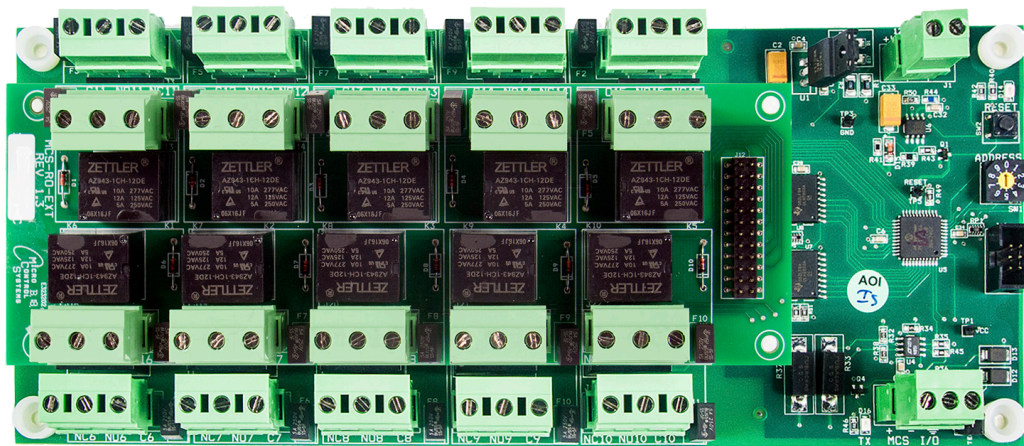

### MCS-RO-BASE and MCS-RO-EXT

- Dimensions .....9.5"l, 4.00"w, 2.50"h
- MCS-RO-BASE.....Mounts on a backplane using four #6 sheet metal screws
- MCS-RO-EXT .....Mounts on top of the MCS-RO-BASE by 4 nylon standoffs and a stacker header (included on MCS-RO-BASE)
- Operating Temperature .....-40°F to +158°F (-40°C to +70°C)
- Operating Humidit .....0-95% Non-Condensing
- Storage Temperature. ....-40°F to +158°F (-40°C to +70°C)
- Microprocessor .....Microchip PIC16F883 @ 8mhz
- Relay Outputs (RO) .....20 outputs 5amps @ 230VAC (total with MCS-RO-EXT)
- Printed Circuit Board.....Four layer with separate power and ground planes
- Input Power (Standard ..... 12VDC input power ±10% @ 77°F (25°C) ambient, 12VA max
- MCS-I/O Comm Port.....1 @ 38,400 Baud
- Power Detection.....Automatic power fail reset

## 2.9. MCS-SI-BASE and MCS-SI-EXT

The MCS-SI-BASE provides a flexible and cost effective way to allow sensor input expansion for MCS MAGNUM-N-12.

Using a Single Output Power Supply the MCS-SI can be used with 115-230 or 24 volt MCS-MAGNUM-N or MicroMag systems.

Using the stackable MCS-SI-EXT you can double the number of inputs and outputs in the same footprint in your enclosure or mounted to a backplane.

### MCS-SI-BASE and MCS-SI-EXT

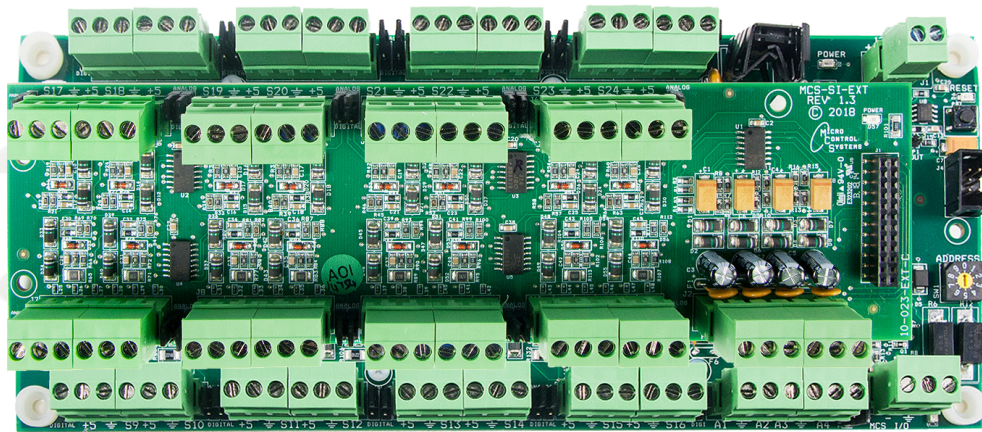

Dimensions .....	8.7"l, x 2.50"w, x 2.50"h
MCS-SI-BASE .....	Mounts on a backplane using four #6 sheet metal screws
MCS-SI-EXT .....	Mounts on top of the MCS-SI-BASE by 4 nylon standoffs and stacker headers (included on MCS-SI-BASE)
Operating Temperature .....	-40°F to +158°F (-40°C to +70°C)
Operating Humidity .....	0-95% Non-Condensing
Storage Temperature .....	-40°F to +158°F (-40°C to +70°C)
Sensor Inputs .....	32 inputs 0-5vdc
Analog Outputs .....	16 outputs 0-10vdc
Printed Circuit Board .....	Four layer with separate power and ground planes
Input Power .....	Powered by MCS-SI-BASE Power
Power Detection .....	Automatic Power Fail - Reset on MCS-SI-BASE

## Theory for settings one MCS-IO-BASE plus extension boards

1. Address settings for installing MCS-IO-BASE and MCS-IO-EXT expansion boards:

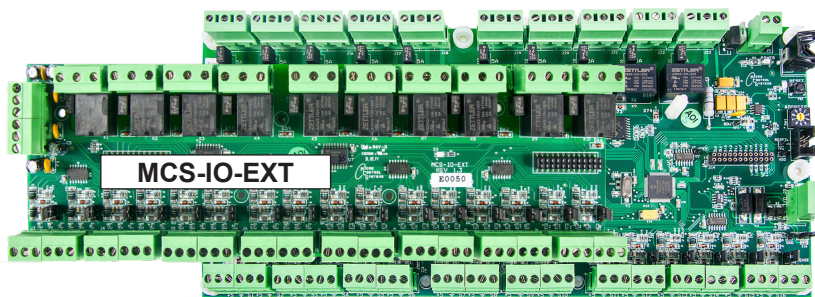

**MCS-IO-Base - Set to #1**  
***Mount a MCS-IO-EXT  
address automatically  
is assigned #2***

2. Adding MCS-RO-BASE, MCS-RO-EXT

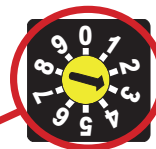
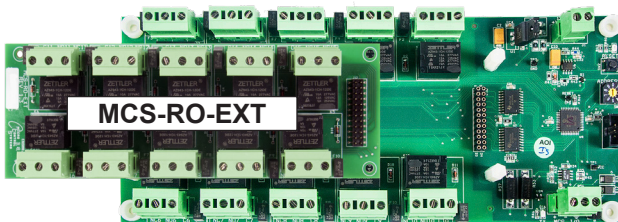

**MCS-RO-Base - Set to #3**  
***Mount a MCS-RO-EXT  
address automatically  
is assigned #4***

3. Adding MCS-SI-BASE, MCS-SI-EXT

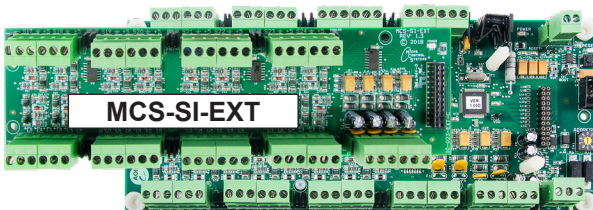

**MCS-SI-Base - Set to #3**  
***Mount a MCS-SI-EXT  
address automatically  
is assigned #4***

**SEE NEXT PAGE - ADDING A SECOND MCS-IO-BASE**

## Theory for settings two MCS-IO-BASE boards plus extension board

1. Address settings for installing MCS-IO-BASE and MCS-IO-EXT expansion boards:

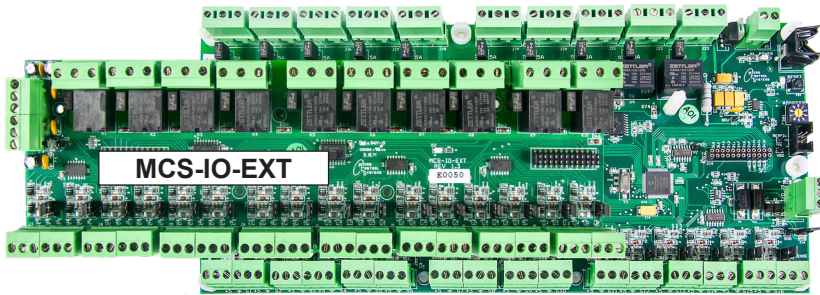

MCS-IO-BASE #1

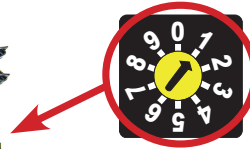

**MCS-IO-Base - Set to #1**  
*Mount a MCS-IO-EXT  
address automatically  
is assigned #2*

2. Adding second MCS-IO-BASE

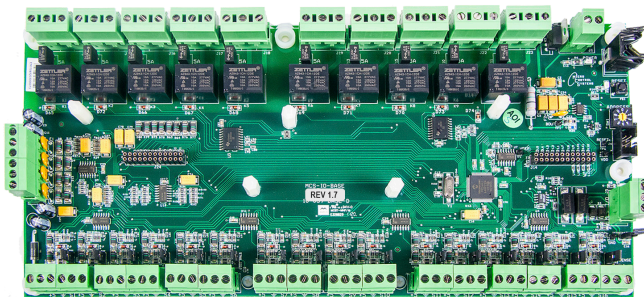

MCS-IO-BASE #2



**MCS-IO-Base - Set to #3**

# Typical Configuration for 3 Chillers

## Complete Plant Controls

- Network connectivity up to 10 Chillers with MCS-Magnum controllers
- Control for multiple chiller water pumps, with primary/standby, rotation, variable speed
- Control for multiple cooling towers with primary/standby, rotation, variable speed

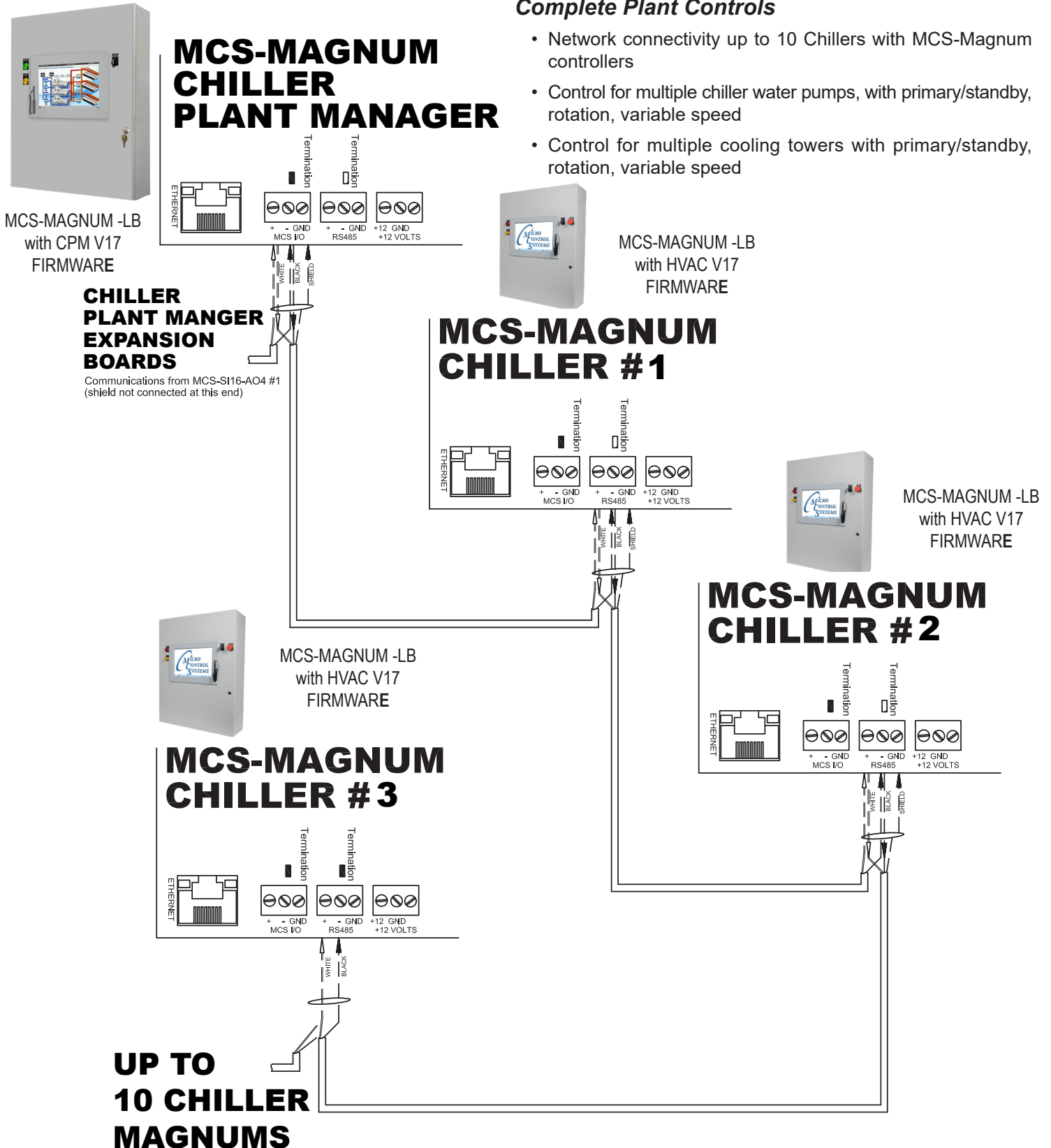

## Chapter - 3. MCS-KEYPAD - Keys and their functions

**KEYPAD SCREEN** - displays current condition of controller. Pressing the Menu key, displays the 10 available Menu items.

- **FUNCTION KEYS** - F1, F2, F3 are used to move between screens, as shown below, F2 - PG↑, F3 - PG↓. Function keys are also used when an numerical digit is needed, F1 = 1, F2 = 2, F3 = 3.
- **ARROW KEYS** - ↓ ↑ ← → used to move between items on screen and also as numerical digits are needed.
- **ENTER KEY** ↵ - used to accept highlighted item on screen and to move to next screen.
- **MENU KEY** - used to move to main menu, also used as numerical digit 8.

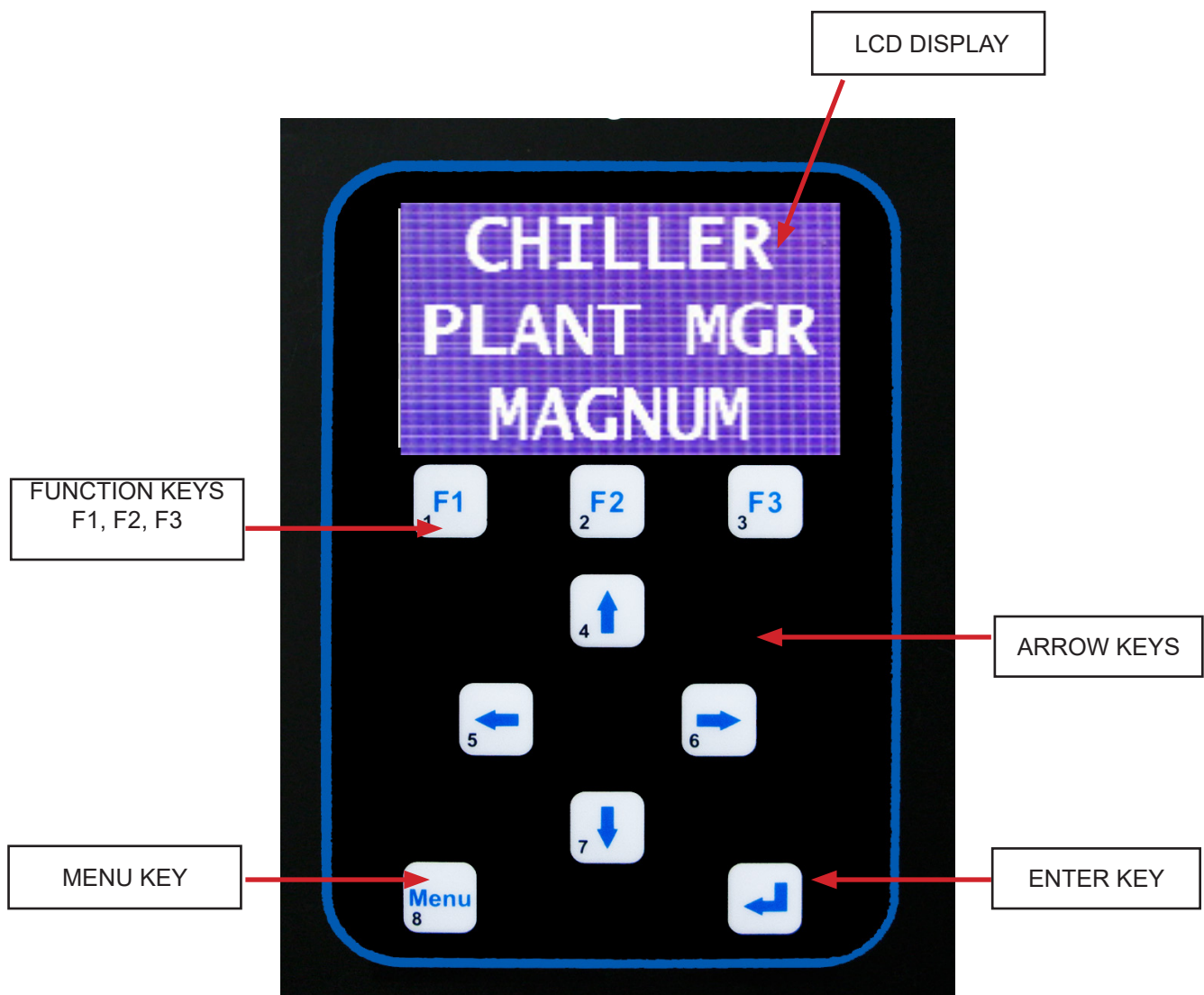



## Chapter - 4. Powering the CPM

1. When the CPM is first powered on, it will enter a 60 second power up delay.
2. After the 60 second delay is satisfied, the CPM will ensure that it is allowed to run by checking for any unit lockout conditions.  
If there are unit lockout conditions, the CPM will lock out all compressors and pumps.
3. If there are no unit lockout conditions, the CPM will check for any stop conditions. If these conditions are satisfied, the CPM will then allow the pumps to operate.

### Stop conditions include the following:

- I. Unit Run/Stop Switch is off
- II. Unoccupied if Schedule is set to shut the unit off
- III. BMS Run Stop Switch=OFF

4. For pump operation, the CPM will check the configuration to ensure that all isolation valves are properly opened before turning on their respective pump groups.
5. Once the pumps are operational and the minimum predelay times are satisfied, the CPM will allow the chiller control to change the unit state, see section CPM STATES.
6. Once the chiller capacity control is allowed, the CPM will use the chiller capacity control algorithm to determine whether the CPM needs to enter cooling mode.

If the CPM Cooling Target setpoint is active, the CPM is allowed to activate its cooling mode.

The temperature to enter cooling mode is determined the following way:

- i. The CPM cooling target is established from Setpoint 4 (CPM Cooling Target)
- ii. The high zone (setpoint 0, Cooling Deadband – High Value) is added to the CPM cooling target

Once the chilled water control temperature rises above the temperature required to enter cooling, the CPM will enter cooling mode.

7. Once the CPM is in cooling, the following conditions will cause it to leave cooling:

### No demand for cooling when CPM is at minimum capacity

- Run stop Condition
- CPM Safety Condition
- All pumps locked out

8. In cooling mode, the CPM will use the standard capacity control algorithm to turn chiller stages on and off as needed, see section 3.4.

### 4.1. Pump Control Algorithm

Depending on the configuration, pump groups can be set up to control a number of different ways.

- Staged based on # of chillers on:
  - Specified in the configuration, up to the max limit of pumps allowed.
- Water Out Temperature
  - This will stage and modulate the pumps in that group to maintain a water out temperature
- Pump Out PSI
  - This will stage and modulate the pumps in that group to maintain a pump out pressure
- Pump Differential Pressure
  - This will stage and modulate the pumps to maintain a differential between the pump in and the pump out pressure

- Before a pump group is allowed on, it will require any necessary isolation valves (if they exist) to be opened. These are determined based off of the following:
  - Pump Group
- Pump Group Type (chilled water vs condenser water)
- Chiller Pump Group (chilled water or condenser water, depends on pump group type)
- Minimum Valves per pump

While in operation, the pump groups will use the setpoints for their respective pump group to control (if the capacity control needs to maintain a temperature or pressure).

- Each pump group uses the standard capacity control algorithm, as described in the standard capacity control section.
- These setpoints are as follows: see section 5 - CPM set points for more information.
  - **Pump Group 1:**
    - Setpoint 11, Pump Group Target
    - Setpoint 12: Pump Group Ratio
    - Setpoint 13: Pump Group Capacity
  - **Pump Group 2:**
    - Setpoint 14, Pump Group Target
    - Setpoint 15: Pump Group Ratio
    - Setpoint 16: Pump Group Capacity
  - **Pump Group 3:**
    - Setpoint 17, Pump Group Target
    - Setpoint 18: Pump Group Ratio
    - Setpoint 19: Pump Group Capacity
  - **Pump Group 4:**
    - Setpoint 20, Pump Group Target
    - Setpoint 21: Pump Group Ratio
    - Setpoint 22: Pump Group Capacity
  - **Pump Group 5:**
    - Setpoint 23, Pump Group Target
    - Setpoint 24: Pump Group Ratio
    - Setpoint 25: Pump Group Capacity

The pump group control will look for both individual pump and pump group faults. These faults will either lock out or put the pump (for individual pump faults) or pump groups (for the group faults) into a safety state.

- The following individual pump faults are supported:
  - No Individual Pump Flow - default name: **'Ind Pmp Flow'**
  - High Amps - default name: **'Hi Pmp Amps'**
  - Low Amps - default name: **'Lo Pmp Amps'**
  - Pump Fault Switch - default name: **'Pmp Fault'**
- The following pump group faults are supported
  - No Pump Group Flow - default name: **'Pmp Grp Flow'**
  - Control SI Fault - default name: **'Pmp Ctrl Flt'**
  - VFD Fault - default name: **'Pmp VFD Flt'**

## 4.2. Chiller Control Algorithm

The chiller control algorithm is used to determine how many chiller stages need to be on in order to maintain a target control temperature.

The algorithm will open isolation valves for each chiller as needed.

The chiller control algorithm will only allow the maximum number of primary chillers (as defined in the configuration) on. The other chillers will not turn on unless one of the primary chillers get locked out.

The chiller control uses the standard capacity control algorithm. It uses the following setpoints: see section 5 for descriptions.

- Setpoint #1: Cooling Deadband (note: only the low zone is used from this setpoint to determine the cooling shutoff temperature)
- Setpoint #3: CPM Cooling Ratio
- Setpoint #4: CPM Cooling Target
- Setpoint #5: CPM Cooling Adjust
- Setpoint #6: CPM Max Dropping ROC

## 4.3. CPM Unit Lockouts

### Freeze protection

- The CPM will lock out the unit due to a freeze protection safety, defined in setpoint #111, value and time delay.

### Control Fault

- If the Control Fault alarm 'SI = ON', the CPM will lock out. The parameters for this lockout are defined in setpoint #34.

## 4.4. Standard Capacity Control Logic

The standard capacity control logic has the following states (note that it includes states for logic that controls above, and below the zone)

- Above Zone and Unloading
- Above Zone Loading
- Below Zone Unloading
- Below Zone Loading
- In Zone Hold
- ROC Unloading
- ROC Loading
- ROC Holding

## Chapter - 5. Common Definitions for Capacity Control Logic

The states above describe what the capacity control function is doing based on the target, and the control value. For example, in the cooling capacity control function, if the control temperature is 50 degrees, and the target is 40 degrees with a zone of 5 degrees on the positive side, the unit will be above zone and loading.

### 5.1. Stage Up Hold

This informs the user that the capacity control is holding while waiting for confirmation that a newly requested stage has turned on.

### 5.2. Staging Delay

This informs the user that the capacity control logic is holding for a predetermined amount of time (set up in the config, or hard coded) because it has just turned on or off a stage.

### 5.3. Fully Loaded

This informs the user that the capacity control is fully loaded.

### 5.4. Fully Unloaded

This informs the user that the capacity control is fully unloaded.

This control strategy is based upon developing a control zone and then to step the compressor(s) through their stages to maintain the control sensor reading within this zone. To accomplish this the system will constantly monitor the control value, its rate of change and position in relationship to the control zone.

The actual strategy of a fixed step system, reciprocating or scroll compressor, and a variable (slide) step system, screw compressor, digital scroll or a reciprocating or scroll compressor with an inverter, is slightly different. The variable step system allows for infinite variations of capacity while the fixed step system does not.

This option is active in all software and is specified in the **MCS-Config** program.

#### 5.4.1 Target

The control target is specified in the appropriate setpoint. This will be the base of developing the control zone.

#### 5.4.2 Control Zone

The control zone is developed by adding the set points for the control target and the zone+ set point to obtain the upper limit. The lower limit is obtained by subtracting the zone- set point from the control target. Some control algorithms (pump control, chiller control without setpoint 6 active) use the same value for both the positive and the negative zone.

Once the control zone has been established, the system will attempt to keep the control sensor reading within this range.

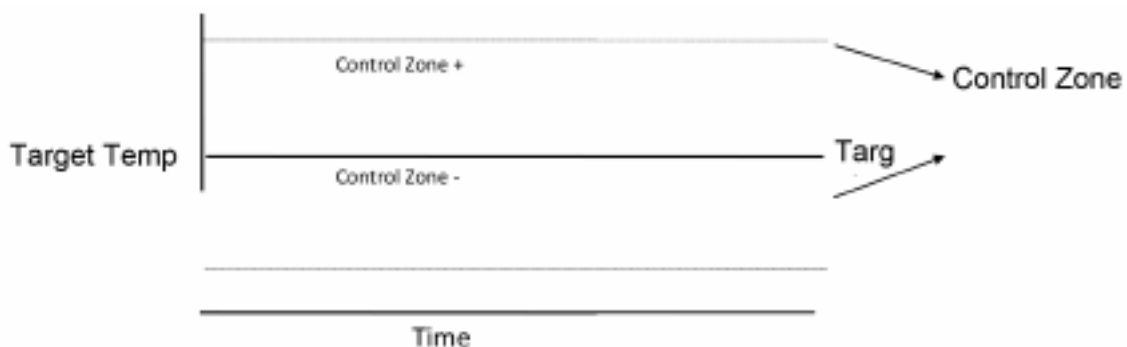

### 5.4.3 Controlling Sensor

This is the sensor that has been specified in the **MCS-Config** program as providing the control value reading. It will normally be either the entering, leaving temperature or the suction pressure. The set points must be adjusted to agree with the controlling value.

### 5.4.4 The Rate of Change of the Control Input

The rate of change is how fast the control value is changing over a period of time. If the control value is increasing the rate will be positive, if decreasing the rate will be a negative value. How fast the input is changing, its direction and where the current input reading is in relationship to the control zone will determine what action the system will take. The maximum rate of change is configurable in MCS-Config. For cooling control, if setpoint 6 is active, there will be separate negative maximum ROC and positive maximum ROC setpoints.

### 5.4.5 Step Delay

The system will not attempt to take action until the Step Delay reaches zero. The initial value is defined in the appropriate set point. The speed that it is decremented by is based upon the integration of the absolute value of the area of the Target – The Current Value of the Controlling Sensor, and the step delay ratio setpoints that have been specified.

## 5.5. Ratio Adjustments

There are two different ratio adjustments. These adjustments control either the speed of the step delay, or by how much the capacity control algorithm adjusts its capacity. The purpose of these ratio adjustments are to both limit, and enhance the speed the system reacts to changes indicated by the control sensor. The higher the multiplier, the faster the system will react. Conversely the higher the divider, the slower the system will react. These are usually set to 1.

The step delay ratio setpoints consist of a multiplier and divider. These setpoints multiply and divide against (respectively) the calculated step delay to determine the final step delay. The final step delay has a minimum limit of 1, and a maximum limit of 20.

The adjust delay ratio setpoints also consist of a multiplier and divider. They work like the step delay ratio setpoints, but rather than controlling the final step delay, they control the final % adjustment to the capacity. The minimum and maximum limits are specified in MCS-Config.

Example

Set Points:

Target = 45° F, Control Zone + = 2 ° F, Control Zone - = 2 ° F, Step Delay = 300, Multiplier = 1, Divider =2

Current Values:

Leaving Liquid = 55 ° F

Using the above values the following would occur:

1. Step delay would reach zero in 60 seconds
  - a. This is because the difference between the target and leaving liquid is 10 degrees, which is then multiplied by 1, and divided by 2. This results in a reduction to the step delay of 5. In order to decrement 300 down to 0, this would need to repeat 60 times.
2. Assuming the lead chiller is ready, it will be turned on.
  - a. Step Delay is reset to its initial value 300. It is not decremented for the amount of time specified in the configuration. Its state would indicate a staging delay, to allow the result of the last change to be evaluated.
3. If the slope calculation is less than specified the step delay will again be decremented and the next available stage will be brought on when it reaches 0.
4. Repeat from step 1

## Chapter - 6. CPM - STATES

We should consider the MCS-MAGNUM controller as a state computer, that is decisions are made based upon setpoints, timers and external data and the controller moves from one state to another. The controller will change states to ensure the proper functioning of the unit.

The control state is displayed on the 2x16 LCD by depressing SERVICE DIAGNOSTIC key and then selecting Control State option or it can be accessed via the MCS-CONNECT program.

### 6.1. CPM Unit States

- **Power Up – “CPM POWER UP DLY”**

- Chiller Chiller Plant Manager goes into a forced 60 second power up state to acquire ROC data for its control algorithms

- **Lockout - “CPM LOCKED OUT”**

- The CPM will go into lockout if the chilled water control temperature SI (leaving water) falls below the freeze protection setpoint, or has a sensor fault. At this point the CPM will cease operation and shut off its chillers, followed by the pumps and isolation valves

- **Scheduled Off - “CPM OFF:SCHEDULE”**

- If the CPM is unoccupied, and the operating schedule setting is set to shut down when un- occupied, the CPM will enter this state. During this mode, the unit will act as if the run/stop switch was turned off.

- **Run Stop Off - “CPM OFF:SWITCHED”**

- If the run/stop switch is turned off, the CPM will shut down all chillers, followed by the pumps, then the isolation valves. During this state, there is no control of the module chillers

- **Pump Only - “CPM ON:PUMP ONLY”**

- During this state, the CPM is on, but there is no demand for cooling. The CPM will only operate its pumps at this point. The CPM will run the pump control logic according to how they are configured for that particular unit.

- **Cooling - “CPM ON: COOLING”**

During this state, the CPM has determined that there is a demand for cooling, based on the CPM Target (setpoint 4) and the deadband (setpoint 1). At this point, the pumps logic will continue running as in pump only, but the chillers will also begin to be controlled to maintain the leaving water temperature.

### 6.2. Individual Chiller States

- **Alarm Off - “CHL IN ALARM OFF”**

Module chiller has been locked out for some reason. CPM will close the isolation valve when it is possible. CPM will not request this chiller to be staged on and will instead use the next available chiller.

- **Off and Ready – “CHL OFF/READY”**

Module Chiller is off, but can be controlled by the CPM. CPM will close the isolation valves for this chiller if not requested by chilled water or condenser water pumps.

- **On – “CHL IS ON”**

Module Chiller is on, its isolation valves open, and is being controlled by the CPM.

- **Opening Isolation Valves - “CHL OPENING VLVE”**

The CPM is opening the isolation valves for the chiller so that it can control the module chiller. If the chiller does not confirm its isolation valves are open, it will go into alarm off mode.

- **Establishing Flow - “CHL WAITING:FLOW”**

The CPM acknowledges a demand for the chiller, but is waiting for flow to be established through the chiller before turning on the chiller.

- **No Pumps Available - “OFF:NO PMP AVAIL”**

The chiller is off and is stuck off due to a lack of pumps available to support it being on.

### 6.3. Individual Pump States

- **Off - “PUMP OFF”**

The pump is off.

- **On – “PUMP ON”**

The pump is on.

- **Anticycle - “PUMP OFF A-CYC”**

The pump is off and in anticycle. Once the anticycle timer is met, the pump state will switch to ‘Off’.

- **Locked Out - “PUMP OFF FAULT”**

The pump has been locked out due to a pump fault.

- **Low Amp Fault - “PUMP OFF LOamp”**

The pump has been locked out due to a low amp fault.

- **High Amp Fault - “PUMP OFF HIamp”**

The pump has been locked out due to a high amp fault.

- **Flow Fault - “PUMP OFF FLOW”**

The pump has been locked out due to a lack of flow.

### 6.4. Pump Group Capacity Control States

- **Group On - “GROUP ACTIVE”**

The pump group capacity control is controlling the pumps as set up in the config.

- **Above Zone Unload - “UNLD OVER ZONE”**

- **Above Zone Load - “LOAD OVER ZONE”**

- **Below Zone Unload - “UNLD UNDR ZONE”**

- **Below Zone Load - “LOAD UNDR ZONE”**

- **In Zone Hold - “HOLDNG IN ZONE”**

- **ROC Unload - “UNLD HIGH ROC”**

- **ROC Load - “LOAD HIGH ROC”**
- **ROC Hold - “HOLD HIGH ROC”**
- **Stage Up Hold - “STAGE UP HOLD”**
- **Staging Delay - “STAGING DELAY”**
- **Fully Loaded - “FULLY LOADED”**
- **Fully Unloaded - “FULLY UNLOADED”**

These states are used by the capacity control algorithm when controlling the pumps on a temperature, pressure, or pressure differential. They describe what state the control algorithm is in based on its control input and the target.

- **Off and Ready**

There is no demand for cooling, because the chilled water temperature is too high, the unit is set to off, or because pump delay setpoints have not been satisfied.



## Chapter - 7. CPM Config Screens

CPM Opening screen – This is where you setup the various screens for controlling the units that will be connected to the Chiller Chiller Plant Manager System.

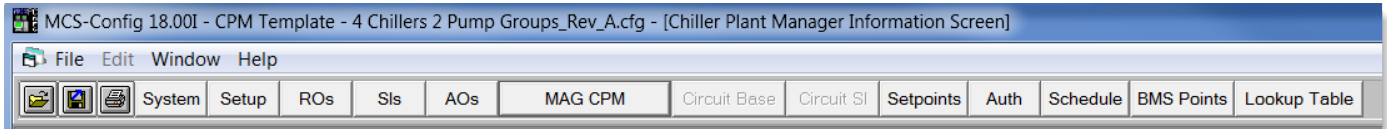

The CPM config software consists of the following screens

- **System**
- **Setup**
- **RO's - Relay Outputs**
- **SI's - Sensor Inputs**
- **AO's - Analog Outputs**
- **MAG CPM Information Screens - used for choosing the points for monitoring the units the CPM will monitor.**
- **Setpoints**
- **BMS Points**
- **Lookup Table(s)**

### 7.1. MAG CPM (MAGNUM Chiller Plant Manager)

Information Panel Selector

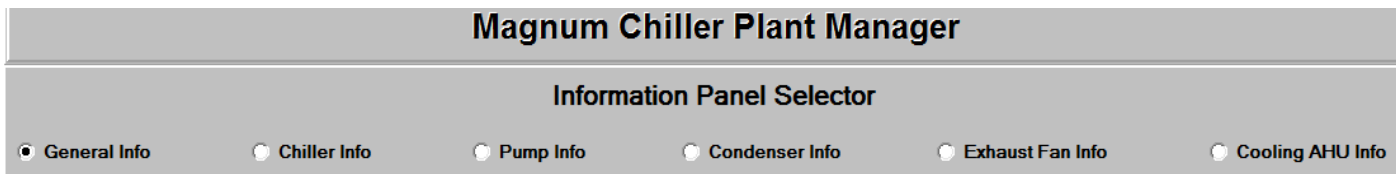

- **General Info**
- **Chiller Info**
- **Pump Info**
- **Condenser Info**
- **Exhaust Fan Info - (Not used at this time)**
- **Cooling AHU Info (Not Used at this time)**

## Chapter - 8. MAG CPM - General Info

### 7.1.1 General Info

Below is the 'GENERAL SCREEN', here you will point to number of chillers, number of primary chillers,

whether the chillers are hardwired, control options and sensors that will points to allowing the CPM to control the state of these chillers.

#### 7.1.1.1. Chillers

The Chiller Chiller Plant Manager will control and monitor up to 10 chillers.

Note: Each Chiller's MAGNUM config must be setup to recognize the CPM.

##### 7.1.1.1.1. 'Primary Chillers'

The chiller control algorithm will only allow the maximum number of primary chillers (as defined in the configuration) on. The other chillers, standbys, will not turn on unless one of the primary chillers get locked out.

##### 7.1.1.1.2. Chillers are Hardwired?

Chillers in the CPM system can be hardwired directly to the CPM's MAGNUM, or connected over the MCS RS485 communication port. See diagram on proceeding pages.

New install, hardwired each chiller to the CPM.

Existing install, use the network communication MCS I/O to RS485 ports, daisy changed at 38400 baud.

**NOTE:** If using an MCS-MODBUS to communicate with a slave unit (Variable Frequency Drive, etc.) on any of the Chillers connected to the CPM you must use the Ethernet port for communication to the CPM MAGNUM.

### 7.2. Relays

Relays can be setup to communicate from each chiller to the CPM MAGNUM relaying the status of the units.

- Alarm RO - CPM can have an alarm or one of the chillers can have an alarm.

Example:

**LOST Magnum #x**

This alarm indicates that Magnum at address x is not communicating.

**ALARMonMagnum #x**

This alarm indicates that Magnum at address x has encountered an alarm.

- Warning RO - shows that a chiller, pump, etc. is in alarm.
- CPM Running Light RO - shows CPM is running.

**Alarm RO**

ALARM ▼

**Warning RO**

Not Used ▼

**CPM Running Light RO**

Not Used ▼

### 7.3. Control Options

- **Chiller Staging Method** -
  - **Variable** - Screw Compressors with slide piston, Compressor with a Variable Frequency Drive (VFD), Modulating compressors, etc.
  - **Fixed** - Reciprocating or scroll compressor.
- **Control On:** - This will be the controlling sensor used to determine the temperature of Chilled water for each chiller. This example the controlling sensor will be 'CW in'.

**Chiller Staging Method:**

Variable     Fixed

---

**Control On:**

CW Out     CW In

### 7.4. Bypass Valves

Bypass valve are used on a system, normally at the end of a loop. They will open and modulate a certain differential pressure to insure continuous flow of the water.

If Chiller one goes down the Isolation Valve will be closed and the Bypass Valve will open allowing the water to continue its flow through the system.

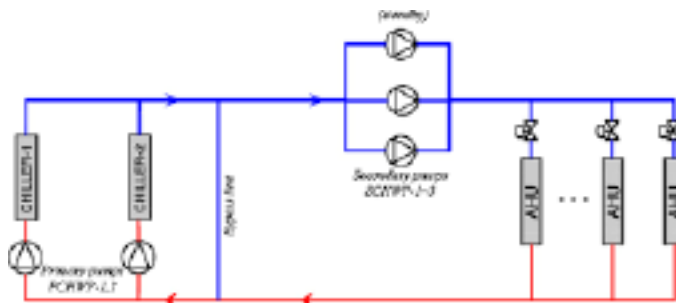

**Chilled Water Has Bypass Valve**

Yes     No

---

**Cooling Tower Has Bypass Valve**

Yes     No

---

**Condenser Water Has Bypass Valve**

Yes     No

### 7.5. Lost BMS Communication

On a loss of communication to the BMS for more than 10 minutes, the controller will default to RUN, STOP or NO CHANGE (if running continue to run or off leave off).

**Lost BMS Communication**

Run     Stop     No Change

**7.6. Isolation Valves Located On:**

The Isolation Valves can be setup to be controlled by each chiller or by the Chiller Chiller Plant Manager.

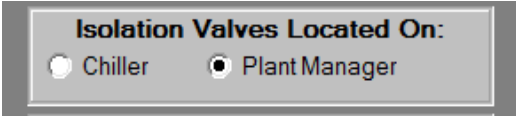

**7.7. Schedule Controls**

**Run /Stop** - If the run/stop switch is turned off, the CPM will shut down all chillers, followed by the pumps, then the isolation valves. During this state, there is no control of the module chillers

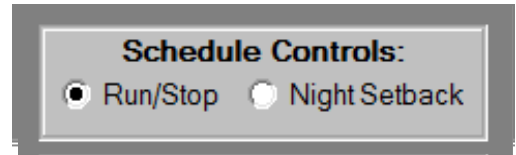

**Night Setback** - If the CPM is unoccupied, and the operating schedule setting is set to shut down when unoccupied, the CPM will enter this state. During this mode, the unit will act as if the run/stop switch was turned off.

**7.8. Staging Method**

**Normal**

More Capacity- The first chiller will be loaded to its full capacity before the next one is enabled to run. It will then be loaded.

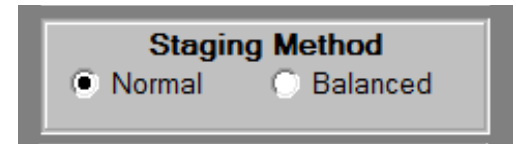

Less Capacity- Lead chiller will be completely unloaded and run enable will be stopped. The next chiller will then be unloaded.

**Balanced**

More Capacity- All chillers will be enabled to run and will be loaded equally.

Less Capacity- All chillers will be unloaded equally.

**7.9. CPM CHILLER ROTATION LOGIC**

The CPM chiller rotation logic works as follows:

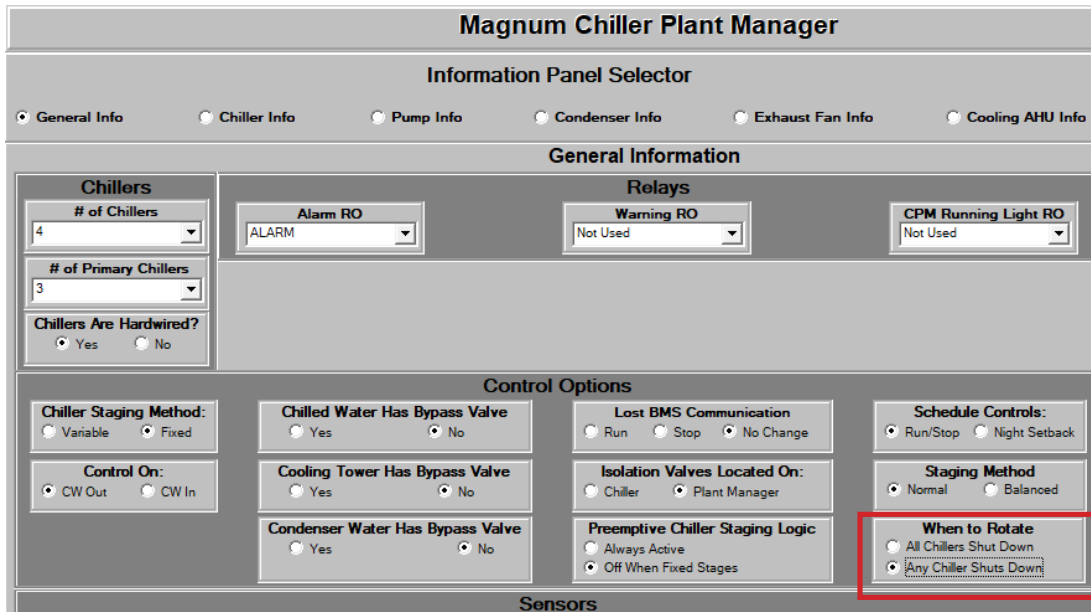

#	Name	Value	Min	Max	Adjust Value	Time (SEC)	Max Time Allowed (SEC)	Lockout Delay (HRS)	Safety Down Time(MIN)	Active or Non-Active	Select Value: # decimals & print char	Level Of Auth. To Display	Type of Setpoint
34	CPM CTRL FLT	1	1	10	1	0	0	0	0	Non-Active	DIGITAL/SW	View Only	Setpoint
35	LEAD CHILLER	0	0	4	1	1	1	0	0	Active	DIGITAL/SW	View Only	Time
36	LD CHL DAYS	0	0	30	1	0	0	0	0	Active	DAYS	View Only	Setpoint

1. If Setpoint #35 “Lead Chiller” has **non zero value**, then there is no chiller rotation and value of the setpoint #35 is the lead chiller.
2. If Setpoint #35 “Lead Chiller” **value is zero**, then chiller rotation is enabled, and setpoint #36 “LD CH Days along with “When to Rotate” option in the config determine when rotation will occur.

- If setpoint #36 value is **non zero value**, then rotation will occur every X days at midnight, where X is the value of setpoint #36. When this option is used and the lead is change is at midnight, the CPM logic will force a chiller off to make sure rotation occurs.
- If setpoint #36 **value is zero**, then chiller rotation will occur based on how the option “When to Rotate” is set in the config file under the MAG CPM General screen (See above clip). If this option is selected as “**All Chiller Shut down**”, rotation will occur only when all chillers have been turn off, either due to temperature or run/stop. If this option is selected as “**Any Chiller Shuts down**”, then rotation will occur when any chiller is stopped due to temperature or chiller disable switch.
- In both A and B cases above the new lead chiller is selected by one of two methods. The method is determined by the value in the Time field of setpoint #35 “Lead Chiller”. If the Time field value **is a zero**, the lead chiller number is increased by 1 until the magnum finds a chiller that is available to run. If the time field in setpoint #35 **is not zero**, then the magnum will find the chiller with the least run time and make it the lead chiller.

## 7.10. Sensors

These are sensor inputs (SI's) that you can point to for various switches, Phase Loss, Ambient Humidity, etc.

Sensors				
Plant Manager Run Switch RUN/STOP	Ambient Humidity Not Used	Building Chilled Water In ChwWtr IN	Chilled Water Reset Not Used	Demand Limit Not Used
Network Run Switch Not Used	Ambient Temp Not Used	Building Chilled Water Out ChwWtrOUT	Light Test Button Not Used	Demand Steps Not Used
Plant Manager Emergency Not Used				
Plant Manager Phase Loss Not Used				

### Plant Manager Run Switch

Mounted on CPM control box allowing the CPM to be manually be stopped or when set to run allowed the CPM to run its algorithm. If the run/stop switch is turned off, the CPM will shut down all chillers, followed by the pumps, then the isolation valves. During this state, there is no control of the module chillers

### Network Run Switch

Same as above, but allows the CPM to stop communicating with the units on the network that it is controlling.

### Demand Limit FLA %

A sensor input can be used to limit how far the compressor can load based on FLA%. Commonly used with infinite capacity screw compressors and Centrifugal compressors.

### Demand Limit Steps

A sensor input can be used to limit the amount of steps of capacity the unit can load to. Typically used with On/Off scrolls or reciprocating compressors with unloaders.

### Light Test Buttons

Points to a sensor mounted in the CPM control box to test that all lights mounted in the control box are functioning.

## Chapter - 9. MAG CPM - Chiller Info

### 9.1. Chiller Info screen.

This screen allows you to setup the controls for the chiller units that are communicating with the CPM.

Setup the Chillers names, network address of the chillers, number of steps for each chillers, etc.

If hardwired to the CPM, enter the information for each chiller.

Chiller Information								
Chiller Setup								
Name	Network Address	Total Number of Steps	Modulate	Chilled Water Pump Group	Chilled Water Isolation Valve(s) RO	Chilled Water Valve(s) Fully Open Feedback	Cooling Tower Group	Cond Water Isolation Valve(s) RO
CHILLER #1	2	4	YES	2	ISO VLV 1	VLV 1 OPEN	Not Used	Not Used
CHILLER #2	3	4	YES	2	ISO VLV 2	VLV 2 OPEN	Not Used	Not Used
CHILLER #3	4	4	YES	2	ISO VLV 3	VLV 3 OPEN	Not Used	Not Used
CHILLER #4	5	6	YES	2	ISO VLV 4	VLV 4 OPEN	Not Used	Not Used
CHILLER #5	1	4	NO	1	Not Used	Not Used	2	Not Used

Chiller Setup					
Chiller	Name	Chilled Water Valve(s) Fully Open Feedback	Cooling Tower Group	Cond Water Isolation Valve(s) RO	Cond Water Valve(s) Fully Open Feedback
1	CHILLER #1	VLV 1 OPEN	Not Used	Not Used	Not Used
2	CHILLER #2	VLV 2 OPEN	Not Used	Not Used	Not Used
3	CHILLER #3	VLV 3 OPEN	Not Used	Not Used	Not Used
4	CHILLER #4	VLV 4 OPEN	Not Used	Not Used	Not Used
5	CHILLER #5	Not Used	2	Not Used	Not Used

Name	Exhaust Fan Group	Cooling AHU Group	"Chiller Running" Light	"Chiller Alarm" Light	Chiller Control Switch	Chiller Disable Switch	Condenser Pump Group	Secondary Pump Group
CHILLER #1	9	5	CHLR 1 RU	CHLR 1 ALI	Not Used	P-PMP1 FI	Not Used	Not Used
CHILLER #2	9	5	CHLR 2 RU	CHLR 2 ALI	Not Used	P-PMP2 FI	Not Used	Not Used
CHILLER #3	9	5	CHLR 3 RU	CHLR 3 ALI	Not Used	P-PMP3 FI	Not Used	Not Used
CHILLER #4	9	5	CHLR 4 RU	CHLR 4 ALI	Not Used	P-PMP4 FI	Not Used	Not Used
CHILLER #5	2	2	Not Used	Not Used	Not Used	Not Used	Not Used	Not Used

Hardwired Chiller Points									
Chiller	Remote Run/Stop RO	Remote Emergency Stop RO	Remote Lockout Reset RO	Remote Chill Water Reset AO	Remote Demand Limit AO	Remote Demand Steps AO	Remote Alarm SI	Remote Stages Available SI	Remote Actual Stages On SI
1	Not Used	Not Used	Not Used	Not Used	Not Used	Not Used	Not Used	Not Used	Not Used
2	Not Used	Not Used	Not Used	Not Used	Not Used	Not Used	Not Used	Not Used	Not Used
3	Not Used	Not Used	Not Used	Not Used	Not Used	Not Used	Not Used	Not Used	Not Used
4	Not Used	Not Used	Not Used	Not Used	Not Used	Not Used	Not Used	Not Used	Not Used

## Chapter - 10. MAG CPM - Pump Info

### 10.1. Pumps and # of Pump Groups Info screen.

Here you specify the number of primary and secondary pumps plus the # of pump groups in the system.

- Control for multiple chiller water pumps, with primary/secondary, rotation, variable speed.
- Up to 15 pumps and 5 pump groups can be controller by the CPM.

**Pump Information**

**Pumps Groups**

# of Pumps

7

# of Pump Groups

2

Pumps										
Pump	Name	Pump RO	Flow Switch	Pump Amps	Pump Fault	Pump Control Switch	Pump Disable Switch	"Pump Running" Light	"Pump Alarm" Light	
▶ 1	SECONDARY PM	S-PMP 1	Not Used	Not Used	S-PMP1 FL	Not Used	Not Used	S-PMP1 RUN	S-PMP1 AL	1
2	SECONDARY PM	S-PMP 2	Not Used	Not Used	S-PMP2 FL	Not Used	Not Used	S-PMP2 RUN	S-PMP2 AL	1
3	SECONDARY PM	S-PMP 3	Not Used	Not Used	S-PMP3 FL	Not Used	Not Used	S-PMP3 RUN	S-PMP3 AL	1
4	PRIMARY PMP 1	P-PMP 1	Not Used	Not Used	P-PMP1 FL	Not Used	Not Used	P-PMP1 RUN	P-PMP1 AL	2
5	PRIMARY PMP 2	P-PMP 2	Not Used	Not Used	P-PMP2 FL	Not Used	Not Used	P-PMP2 RUN	P-PMP2 AL	2
6	PRIMARY PMP 3	P-PMP 3	Not Used	Not Used	P-PMP3 FL	Not Used	Not Used	P-PMP3 RUN	P-PMP3 AL	2
7	PRIMARY PMP 4	P-PMP 4	Not Used	Not Used	P-PMP4 FL	Not Used	Not Used	P-PMP4 RUN	P-PMP4 AL	2
8	PUMP #8	Not Used	Not Used	Not Used	Not Used	Not Used	Not Used	Not Used	Not Used	2

#### 10.1.1 Pump Group

Depending on the configuration, pump groups can be setup to control a number of different ways.

- **Staged based on # of Chillers on:** Specified in the configuration, up to the max limit of pumps allowed.
- **Stage on Water Out Temp:** This will stage and modulate the pumps in that group to maintain a water out temperature.
- **Stage on Pump Out PSI:** This will stage and modulate the pumps in that group to maintain a pump out pressure
- **Stage on Differential PSI:** This will stage and modulate the pumps to maintain a differential between the pump in and the pump out pressure.

Pump Group								
Pump Group	Control Type	# of Pumps on per Chiller	# of Pumps to Force On	Max Pumps Allowed On	Max Pumps Per Chiller	Min Valves Per Pump	# of Cond Valves to Force On	Min Pumps Per Cond
▶ 1	Stage on Pump Out PSI	0	2	2	10	0	0	0
2	Stage Based on # of Chillers on	0	3	3	10	1	0	0
3	Stage Based on # of Chillers on	1	1	1	10	0	0	0

Pump Group									
Pump Group	Min Cond Valves Per Pump	Water Out Temperature	Pump Out PSI	Pump In PSI	Pump VFD AO	Flow Switch	VFD Fault	Pumps Off When Unoccupied	Pump Group Typ
▶ 1	0	Not Used	SPmpDifPs	Not Used	S-PMP 1?	Not Used	Not Used	NO	Chilled Water
2	0	Not Used	Not Used	Not Used	Not Used	Not Used	Not Used	NO	Chilled Water
3	0	Not Used	Not Used	Not Used	Not Used	Not Used	Not Used	NO	Chilled Water

## Chapter - 11. MAG CPM - Condenser Info

### 11.1. # of Condensers

Control for up to 10 condensers.

Setup for Starting condenser, total # of Stages, Flow Switch, Faults and Condenser Group number.

Condenser Information												
Condensers												
# of Condensers												
3												
Condensers												
Cond	Name	Starting Cond	Total # of Stages	Flow Switch	Starting Cond Fault	Total # of Faults	Starting Cond Disable Switch	Total # of Disable Switches	Cond Isolation Valve(s) RO	Cond Valve(s) Fully Open Feedback	Cond Group #	
1	Cooling T1	CT-1 FANS	1	Not Used	CT-1ATRIP	6	CT-1AAUTO	6	CTMV-1 ON	CT3SupStat	2	
2	Cooling T2	CT-2 FANS	1	Not Used	CT-2ATRIP	6	CT-2AAUTO	6	CTMV-2 ON	CT AMB TMP	2	
3	Cooling T3	CT-3 FANS	1	Not Used	CT-3ATRIP	6	CT-3AAUTO	6	CTMV-3 ON	SPARE6-15	2	
4	Cooling T4	Not Used	1	Not Used	Not Used	0	Not Used	0	Not Used	Not Used	1	

#### 11.1.1 Condenser Control Switches, Lights

Setup for pointers to Control switches, Alarm Lights and stages allowed.

Condensers								
Cond	Cond Control Switch	Starting "Cond Running" Light	Total # of Running Lights	Starting "Cond Alarm" Light	Total # of Alarm Lights	Min Stages Allowed	Max Faults Allowed	
1	Not Used	CT-4 FANS	1	Not Used	0	0	3	
2	Not Used	Not Used	1	Not Used	0	0	0	
3	Not Used	Not Used	1	Not Used	0	0	0	

#### 11.1.2 Condenser Groups

Setup for what is the Condenser Group, is the group active, what Chiller pumps, what AO is controlling, etc.

Condenser Groups										
Cond Group	Cond Group Active?	Control Type	Follow Chillers / Pumps	Group Variable Output AO	# of Cond on per Chiller / Pump	# of Stages to Force On	Max Towers Allowed On	Max Towers Per Chiller / Pump	Water Out Temperature	Water In Temperature
1	NO	Stage Based On Water Out Tem	Chillers	Not Used	0	0	0	0	Not Used	Not Used
2	YES	Stage Based On Water Out Tem	Pumps	CT VSD	0	1	3	10	CND PT-5	CndTS-CO
3	NO	Stage Based On Water Out Tem	Pumps	Not Used	0	0	0	0	Not Used	Not Used



## Chapter - 12. MAG CPM - Exhaust Info

### 12.1. Not programmed into firmware yet.

Exhaust Fan Information									
Exhaust Fans Groups									
# of Exhaust Fan Groups									
0									
Exhaust Fan Group	Name	Starting Exhaust Fan	Total # of Stages	Max Stages Allowed On	Starting Exhaust Fault	Starting Exhaust Fan Control Switch	Starting Exhaust Fan Disable Switch	Starting "Exhaust Fan Running" Light	Starting "Exhaust Fan Alarm" Light
▶ 1	EXHAUST FAN #1	ISO VLV 1	1	1	Not Used	Not Used	Not Used	Not Used	Not Used
2	EXHAUST FAN #2	ISO VLV 1	1	1	Not Used	Not Used	Not Used	Not Used	Not Used
3	EXHAUST FAN #3	ISO VLV 1	1	1	Not Used	Not Used	Not Used	Not Used	Not Used
4	EXHAUST FAN #4	ISO VLV 1	1	1	Not Used	Not Used	Not Used	Not Used	Not Used
5	EXHAUST FAN #5	ISO VLV 1	1	1	Not Used	Not Used	Not Used	Not Used	Not Used
6	EXHAUST FAN #6	ISO VLV 1	1	1	Not Used	Not Used	Not Used	Not Used	Not Used
7	EXHAUST FAN #7	ISO VLV 1	1	1	Not Used	Not Used	Not Used	Not Used	Not Used
8	EXHAUST FAN #8	ISO VLV 1	1	1	Not Used	Not Used	Not Used	Not Used	Not Used
9	EXHAUST FAN #9	ISO VLV 1	1	1	Not Used	Not Used	Not Used	Not Used	Not Used
10	EXHAUST FAN #10	ISO VLV 1	1	1	Not Used	Not Used	Not Used	Not Used	Not Used

## Chapter - 13. MAG CPM - Cooling Info

### 13.1. Not programmed into firmware yet.

Cooling AHU Information											
Cooling AHU's Groups											
# of Cooling AHU Groups											
0		Cooling AHU Group	Name	Starting Cooling AHU	Total # of Stages	Max Stages Allowed On	Starting Cooling AHU Fault	Starting Cooling AHU Control Switch	Starting Cooling AHU Disable Switch	Starting "Cooling AHU Running" Light	Starting "Cooling AH Alarm" Light
▶	1	COOLING AHU #1	Not Used	1	1	Not Used	Not Used	Not Used	Not Used	Not Used	Not Used
	2	COOLING AHU #2	Not Used	1	1	Not Used	Not Used	Not Used	Not Used	Not Used	Not Used
	3	COOLING AHU #3	Not Used	1	1	Not Used	Not Used	Not Used	Not Used	Not Used	Not Used
	4	COOLING AHU #4	Not Used	1	1	Not Used	Not Used	Not Used	Not Used	Not Used	Not Used
	5	COOLING AHU #5	Not Used	1	1	Not Used	Not Used	Not Used	Not Used	Not Used	Not Used

## Chapter - 14. Magnum CPM Setpoints

Setpoint Information Screen

#	Name	Value	Min	Max	Adjust Value	Time (SEC)	Max Time Allowed (SEC)	Lockout Delay (HRS)	Safety Down Time(MIN)	Active or Non-Active	Select Value: # decimals & print char	Level Of Auth. To Display	Type of Setpoint	Comments	SEC to Ignore Safety	Window to Ext. Safety Time(SEC)	Safety Time Extension (SEC)
---	------	-------	-----	-----	--------------	------------	------------------------	---------------------	-----------------------	----------------------	---------------------------------------	---------------------------	------------------	----------	----------------------	---------------------------------	-----------------------------

**# (Number)–From 1 to 255** (maximum number of Setpoints supported). Only active Setpoints will be displayed in MCS-Connect and on the keypad display.

**Name–The Setpoint’s name consists of up to 12 characters.** The name is displayed following the number on the LCD display. The Setpoint name can be changed to make it more meaningful to the current application, however the function of the Setpoint will remain the same.

**Value–The value or target of the Setpoint.** With proper authorization this value can be changed, within limits that have been established in MCS-Config.

**Min–The minimum value that can be set.** This field is not displayed and cannot be changed in MCS-Connect or in the keypad display.

**Max–The maximum value that can be set.** This field is not displayed and cannot be changed in MCS-Connect or in the keypad display.

**Adjust Value–The interval that the value field can be changed by.** This field is not displayed and cannot be changed in MCS-Connect or in the keypad display.

**‘Time (sec)’ – this field has two purposes:**

1) In either a LOCKOUT or ALARM type; this is the length of time the Setpoint must be true before it will trip. This time is always in seconds and it is displayed on the keypad display and MCS-Connect if the Setpoint is either a LOCKOUT or ALARM type. This field can be changed in MCS-Connect and through the keypad.

2) In a non-safety type Setpoint this field can be used as an extra timer. This will be specified in the Setpoint definition if it is used.

**Lockout Delay Hrs.** – If a second safety occurs within this time, the unit or compressor will be locked out. This field is not displayed and cannot be changed through MCS-Connect or in the keypad display.

**Safety Down Time (min.)** – After the first safety occurs the Magnum will wait this number of minutes before the unit or associated compressor is allowed to run again.

**Active or Non-Active** – Only active Setpoints will be displayed in MCS-Connect or on the keypad display, but only if the needed authorization level has been achieved.

**Select Value: # decimals and print char** – This indicates the number of decimal places and the unit character that accompanies the value displayed. The number of decimal places is crucial when the Value, Minimum, and Maximum data is entered in MCS-Config.

**Level of Auth. To Display** – This column indicates what authorization level a user must have in order to view the Setpoint from MCS-Connect or the keypad display.

**Comments** – This column allows the user to add comments about the function of the Setpoint.

**BMS Writeable (Click Here to Disable All)** – The Magnum software will enable communications with an outside source, building management system (BMS), to modify the value of a set point. Object is to provide maximum flexibility and capability with an BMS.

## 14.1. Setpoint Types

*There are EIGHT different types of Setpoints. The Magnum CPM software determines if a Setpoint contains a target value or is a safety. If it is a safety then its type determines what action the Magnum will take when the safety occurs (either locking out the unit or generating an alarm only).*

### 14.1.1 SETPOINT

This type of Setpoint contains a target or provides information for some action. The time element in this type can be used for an additional counter if specified. This time is not displayed and cannot be changed through MCS-Connect or from the keypad display.

### 14.1.2 LOCKOUT

This type of Setpoint contains a safety value and the time that the safety must be violated before the safety will trip. Once a safety has tripped the Magnum will take the appropriate action, shutting down the entire package or an individual compressor depending on the purpose of the safety. The Magnum will then wait the Safety Down Time contained in that Setpoint before trying to return the normal. If successful, the system will continue to operate. If a second trip occurs on the same Setpoint within the Lock Out Delay Time that is contained in that Setpoint the system will move to a LOCKOUT state. If the lockout delay time is set to zero the lockout will occur on the first trip. This requires manual intervention to reset the system. With each safety trip, the Magnum will generate an alarm; refer to section 8 Magnum Alarms and Safeties.

**Sec. to ignore safety** - If this value is not zero, at compressor startup this safety will be ignored for the time in this field.

**Window to extend Safety 'Time (sec)'** – If this value is not zero, at compressor startup the normal Safety Time will be increased by the value in Safety Time Extension field for the time specified in this field.

**Safety Time Extension (Sec)** – This is the value that will be added to the Safety Time during the Window to extend Safety Time period.

### 14.1.3 ALARM

This type of Setpoint has two uses:

- 1) When it is used as a safety, it will be similar to the LOCKOUT Setpoint except it will never cause a lock out. The system will continue to try returning to normal operation after waiting the safety down time. An ALARM Setpoint type will never require manual intervention to reset the system.
- 2) When the Setpoint is being used as a second timer it will be available to change in a live unit. If the type is not changed to ALARM then the time field cannot be viewed or changed from a live unit.

**Sec. to ignore safety** - If this value is not zero, at compressor startup this safety will be ignored for the time in this field.

**Window to extend Safety 'Time (sec)'** – If this value is not zero, at compressor startup the normal Safety Time will be increased by the value in Safety Time Extension field for the time specified in this field.

**Safety Time Extension (Sec)** – This is the value that will be added to the Safety Time during the Window to extend Safety Time period.

### 14.1.4 TIME

This type of Setpoint allows the 'Time (SEC)' value to be displayed and modified in a live unit.

### 14.1.5 TARGET

This type of set point is used to develop a target with a high and low zone values.

The decimal characteristics of these values are the same as the Value field

**High Zone** – The value of this cell is added to the Value cell to create the high zone value.

**Low Zone** – The value of this cell is subtracted from the Value cell to create the low zone value.

**Night Setback** – If system has an unoccupied mode, this value is used to modify the value of the 'Value' cell.

### **14.1.6 CPM TARGET**

Determines the target temperature for chillers to maintain.

Determines the step delay for chiller capacity control.

Determines the zone value (both positive and negative) for chiller capacity control.

Determines the maximum positive ROC for chiller capacity control.

Determines the period of time over which current ROC is calculated (to determine value to put in, divide desired ROC Interval by 10 for current version)

### **14.1.7 CPM RATIO**

Multiplier A: Determines the numerator value for chiller capacity % adjustment scaling (variable chillers only)

Divider A: Determines the denominator value for chiller capacity % adjustment scaling (variable chillers only)

Multiplier B: Determines the numerator value for scaling the step delay decrement.

Divider B: Determines the denominator value for scaling the step delay decrement.

### **14.1.8 DELAY**

This type of set point is used to develop a target with a high and low zone values.

The decimal characteristics of these values are the same as the Value field

**High Zone** – The value of this cell is added to the Value cell to create the high zone value.

**Low Zone** – The value of this cell is subtracted from the Value cell to create the low zone value.

**Night Setback** – If system has an unoccupied mode, this value is used to modify the value of the 'Value' cell.

## Chapter - 15. CPM - SET POINTS

Setpoint #	Setpoint Name	Description	Type	Function Description
1	CoolDeadband	High Zone	Target	Adds to the CPM Target to determine cut in temperature for Cooling
1	CoolDeadband	Low Zone	Target	Subtracts from the CPM Target to determine cut off temperature for Cooling
2	Not used			
3	CPM Ratio	Value	CPM Ratio	Multiplier A: Determines the numerator value for chiller capacity % adjustment scaling (variable chillers only)
3	CPM Ratio	Divider A	CPM Ratio	Divider A: Determines the denominator value for chiller capacity % adjustment scaling (variable chillers only)
3	CPM Ratio	Multiplier B	CPM Ratio	Multiplier B: Determines the numerator value for scaling the step delay decrement
3	CPM Ratio	Divider B	CPM Ratio	Divider B: Determines the denominator value for scaling the step delay decrement
4	CPM Target	Value	CPM Target	Determines the target temperature for chillers to maintain
4	CPM Target	Time	CPM Target	Determines the step delay for chiller capacity control
4	CPM Target	Zone	CPM Target	Determines the zone value (both positive and negative) for chiller capacity control. When setpoint #6 is active, setpoint #4 zone is no longer used.
4	CPM Target	Max ROC	CPM Target	Determines the maximum positive ROC for chiller capacity control
4	CPM Target	ROC Interval	CPM Target	Determines the period of time over which current ROC is calculated (to determine value to put in, divide desired ROC Interval by 10 for current version)
5	CPM Adjust	Value	Delay	Determines minimum % adjustment for chiller capacity (variable chillers only)
5	CPM Adjust	Min VFD Opening	Delay	Indicates the minimum amp draw, slide %, digital scroll load%, or speed allowed (usually 40%).
5	CPM Adjust	Max VFD Opening	Delay	Indicates the maximum amp draw, slide %, digital scroll load%, or speed allowed.
5	CPM Adjust	Max VFD Adjustment	Delay	Determines maximum % adjustment for chiller capacity (variable chillers only)
6	CPM Max ROC-	Value	Target	Compares the control value rate of change. Maximum negative Rate of Change allowed before preventing the unit from loading. If the ROC is less than this value the capacity control state is set to HOLDING.
6	CPM Max ROC-	High Zone	Target	Added to the CPM TARGET to create the upper limit of the control zone.
6	CPM Max ROC-	Low Zone	Target	Subtracted from the CPM TARGET to create the lower limit of the control zone.
7,8,9,10	Not Used			
11	PumGrp 1 Trgt			
12	Pump Group 1 Ratio	Multiplier B	CPM Ratio	Adjust Delay Multiplier for pump group 1
12	Pump Group 1 Ratio	Divider B	CPM Ratio	Adjust Delay Divider for pump group 1
13	Pump Group 1 Capacity	Value	Delay	Min Adjustment % for pump group 1

Setpoint #	Setpoint Name	Description	Type	Function Description
13	Pump Group 1 Capacity	Min VFD Opening	Delay	Max Capacity % for pump group 1
13	Pump Group 1 Capacity	Max VFD Opening	Delay	Min Capacity % for pump group 1
13	Pump Group 1 Capacity	Max VFD Adjustment	Delay	Max Adjustment % for pump group 1
14-25	Pump Groups 2-5 Control Setpoints			Same as 11-13 except for groups 2-5
26	PmpA-C On-On	Value	Setpoint	Determines the minimum amount of time between pumps turning on
27	COff-On	Value	Setpoint	Determines the minimum amount of time after a pump turns off before it is allowed to turn on again
28	Pump Hi Amps		Alarm/Lockout	Pump Hi Amps Safety
29	Pump Low Amps		Alarm/Lockout	Pump Low Amps Safety
30	Pump Group Control Fault		Alarm/Lockout	Safety for pump group control sensor fault
31	Not Used			
32	Pump Group VFD Fault		Alarm/Lockout	Safety for Pump Group VFD Fault input
33	PMP GRP FLOW		Alarm/Lockout	Standard lockout logic for pump group flow based off of flow switch on pump groups
34	CPM Control Fault		Lockout Only	Standard Lockout logic for chilled water control temperature sensor
35	LEAD CHILLER		Time	If "Lead Chiller" has non zero value, then there is no chiller rotation and value of the setpoint is the lead chiller. If "Lead Chiller" value is zero, then chiller rotation is enabled, and setpoint #36 "LD CH Days along with "When to Rotate" option in the config determine when rotation will occur.
36	LD CHL DAYS		Setpoint	If setpoint value is <b>non zero value</b> , then rotation will occur every X days at midnight, where X is the value of setpoint #36. When this option is used and the lead is changed at midnight, the CPM logic will force a chiller off to make sure rotation occurs.  If setpoint <b>value is zero</b> , then chiller rotation will occur based on how the option "When to Rotate" is set in the config file under the MAG CPM General screen. If this option is selected as "All Chiller Shut down", rotation will occur only when all chillers have been turned off, either due to temperature or run/stop. If this option is selected as "Any Chiller Shuts down", then rotation will occur when any chiller is stopped due to temperature or chiller disable switch.  In both A and B cases above, the new lead chiller is selected by one of two methods. The method is determined by the value in the Time field of setpoint #35 "Lead Chiller". If the Time field value is a zero, the lead chiller number is increased by 1 until the magnum finds a chiller that is available to run. If the time field in setpoint #35 is not zero, then the magnum will find the chiller with the least run time and make it the lead chiller.
37	Group 1 Lead Pump		Time	Like Lead Chiller, except for Pump Group #1
38	Group 1 Lead Pump Days		Setpoint	Like Lead Chiller Days, except for Pump Group #1
39-46	Groups 2-5 Lead Pump + Days			Same as 37-38, except for pump groups 2-5

Setpoint #	Setpoint Name	Description	Type	Function Description
47	Pump Group #1 Pre- Delay	Value	Setpoint	Determines minimum amount of time pump must have flow before chillers are allowed on
48	Pump Group #1 Post- Delay	Value	Setpoint	Determines how long after run stop switch is flipped that at least one pump stage will continue to run
49	Not Used			
50-56	Pump Group #2-5 Pre/ Post Delay			Same as 47-48 except for pump groups 2-5
57	Individual Pump Flow Fault		Alarm/Lockout	Standard Safety logic for individual pump flow switches
58	Max Target Reset		Setpoint	Standard Max Target Reset Setpoint for chilled water reset
59	Cooling Staging Delay	Value	Setpoint	This setpoint determines how long cooling will hold in a staging delay once a stage is added or subtracted from the capacity
60	Isolation Valve Close Delay	Value	Setpoint	When a chiller shuts down due to lockout or normal shutdown, this setpoint defines how long the CPM will wait before closing the isolation valve for that chiller. If this setpoint is inactive, it will default to 30 seconds.
61	Isolation Valve Proof Lockout		Lockout Only	If active, this setpoint will lock out a chiller if an isolation valve is requested open for a certain period of time (defined by the setpoint) and proof is not given to the CPM.
62-104	Not Used			
105	IndPmpVfdFit			
106	Stage Off Delay		Setpoint	The amount of time to wait after the CPM sets the associated chillers run/stop to stop before cycling off the pump and closing the isolation valve. (For hard wired)
107	Stage On Delay		Setpoint	Once the CPM asks for a chiller to start it will open the isolation valve wait for proof of valve being open, and once the pump starts this is the amount of time to wait prior to the CPM sending the RUN command to the chiller. (For hard wired)
108	Below Minimum Valve Time	Seconds	Setpoint	The value field will be the time the CPM chill water pump will run while below the required amount of isolation valves before shutting down the CPM and stopping the chill water pump. (SETPOINT, SECONDS)
109	NO COMP AVL	Seconds	Setpoint Value	If the chiller reports steps available and we go into the "CHL IS ON" state and the actual capacity ON does not increase by one prior to the timer expiring in this setpoint then that chiller will be disabled for three minutes(hard coded) and an alarm will be posted in the alarm grid. After three minutes this chiller will become available again for the CPM to try again. The value of this setpoint can't be set below 65 seconds as its hardcoded.
110	Not Used			
111	FREEZE			Standard lockout logic for unit freeze protection based on chill water control temperature (in or out depending on config)
112	CHL NO FLOW	SECONDS	Lockout	Once the chiller has valve proof the CPM will look at the value in this setpoint and start the timer and enter waiting for flow state. If the timer expires the CPM will lock out the chiller and move onto the next.



**PAGE LEFT BLANK**



*Providing HVAC/R Control Solutions Worldwide*

5580 Enterprise Pkwy. Fort Myers, FL 33905

Office: (239) 694-0089

Fax: (239) 694-0031

[www.mcscontrols.com](http://www.mcscontrols.com)